

VIS - Laser Marking System

10-20-30-40W

System Overview

All Automator YAG lasers are manufactured with the highest quality sources available. VIS is a laser unit extremely light and solid, which perfectly adapts to integrations of lines. Thanks to the source Vanadate YVO_4 , the laser is able to mark, permanently, various materials such as steel, anodized aluminium and painted surfaces, iron, cast iron and plastic. All the components are integrated in the practical carter: from the source to the electrical cards; up to the scanning head with a flat lens. The Vis model was created and produced, under the respects of the "Blue Philosophy" and under the common regulations for the well being of nature and energy consumption reduction. Automator has adopted these initiatives, not only in the choice of the components but even in the settings of the internal production mechanism; for this, Vis is a environment-friendly laser device.



Basic Configuration

Stand Alone Configuration

PC (Not included)

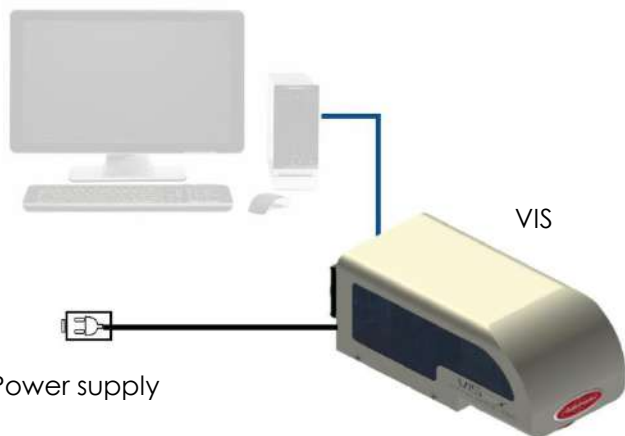

Automation

Production line

PC (Not included)

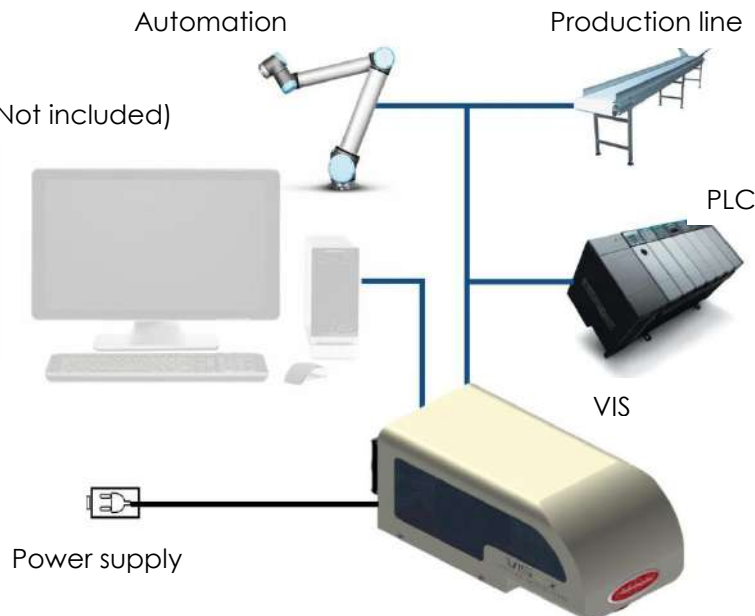

System Configurations

VIS is available in two software/hardware configurations: BASIC or STAND ALONE, with three power sources models: 10W, 20W, 30W and 40W.

Options

Adjustable X-Y-Z axis, Rotating Theta axis, Safety Class 1 enclosures

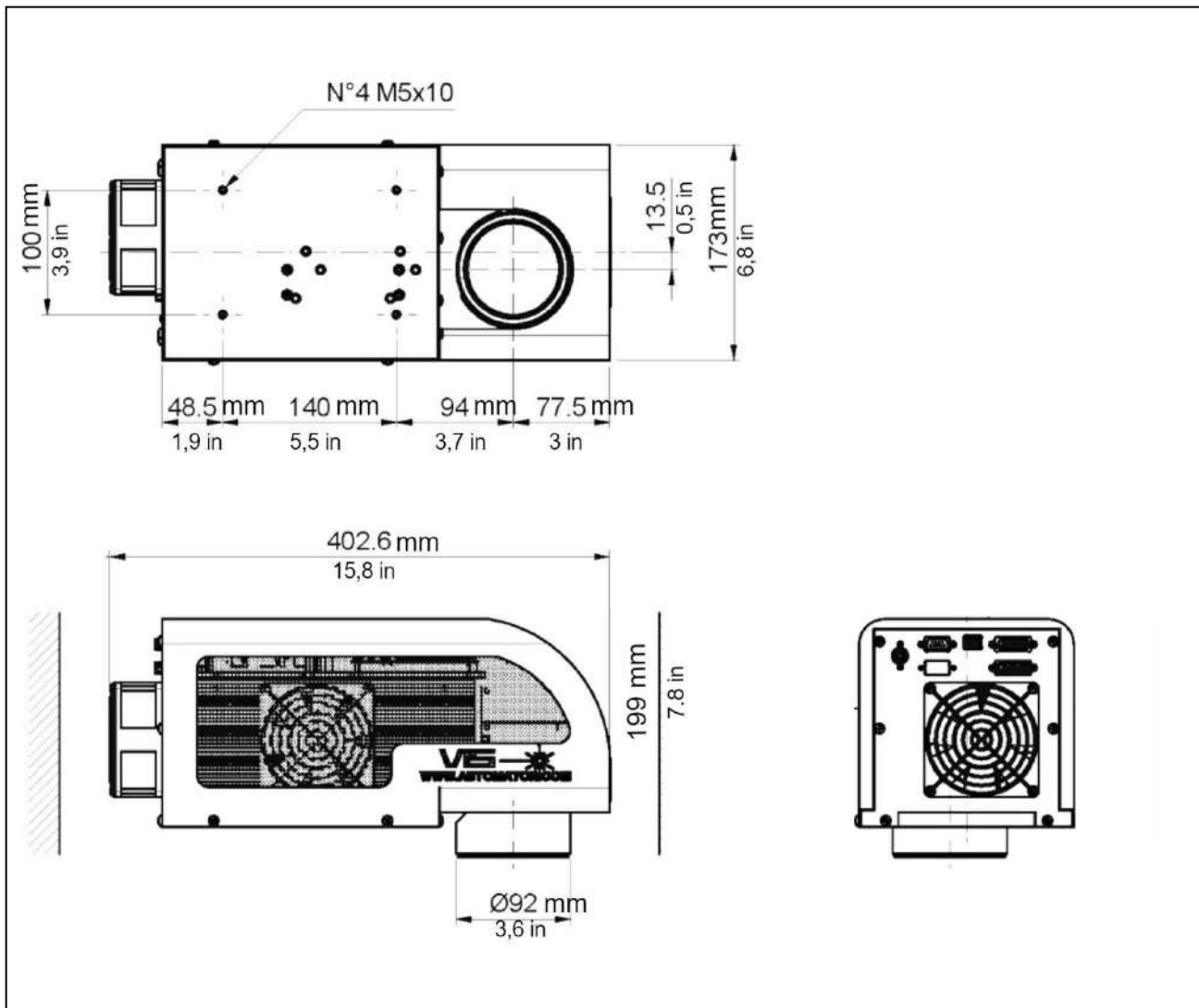
Technical drawings

Galvanometric Head

The galvanometric head, integrated in the carter Vis, is a device which acts to deflect the laser beam in two dimensions to project on the piece to be marked images, figures and other general marking necessities. Two mirrors mounted on the galvanometers at high power form the head. Above and beneath the mirrors are the fixed focalising optics; in addition even the flat field lens define the marking area and the focal length from the object to be marked. The laser source is assembled and sealed in a white room, without contaminating agents, in order to prevent any type of pollution, which could reduce the life of the crystal or of the resonator. The unity is equipped with an electro-mechanics shutter that has the role of reassuring security when the laser is active; the open shutter permits the passage of the ray through the galvanometric head's lenses up to the piece to be marked. With a closed shutter (through the signal of I/O or machine stop), the ray does not pass.

Automator VIS - Marking laser

Box unit - Technical data

Overall Dimensions: LxWxH (mm • in):	402x199x173 • 15,8x7,8x6,8
Weight (kg - lb):	11 • 56,21
Laser type:	YAG
Power range (W):	10 - 20 - 30 - 40
Wavelength (nm):	1064
Polarization:	Linear 100:1
Standard lens (mm - marking area):	F160 - marking area 110x110
Optical Isolator:	NO
External power supply:	100/240V 50/60Hz (converter 24V provided)
Power consumption (20°C) (W):	220/220/300/600
Laser working voltage (VDC):	24 ± 1
Laser beam diameter, before lenses (mm):	5.7 - < 8
Beam quality (M ²):	<1.8 - < 2.13
Pulse duration (ns) @20kHz:	24 - 15 - 14
Output power tunability (%):	0-100
Operating temperature (°C • °F):	0 - +39 • 32 - 100,4
Store temperature (°C • °F):	-10 - +60 • 14 - 140
Humidity (%):	30 - 85
Cooling system:	Forced air cooled - Water (optional)
Connectivity:	Power, ethernet port, I/O port
Directive 2011/65/EC - Restriction of Hazardous Substances (RoHS):	Respectful
Safety Class:	4
MTBF (Working Hours):	120.000
IP Certification of the Cover: (CEI70-1)	30
Mark on fly:	YES
Available axis (depending by the softwares):	Z-X-Y and Rotating Theta

Red Pointer Diode

The laser produces a red, visible light, known as pointer, which allows visualizing the working area directly on the surface of the object, without altering it's nature or starting the marking. For its wavelength, the operator does not need to wear the DPI protection, while he proceeds for the setting, the programmation or the marking trials of the laser.

Automator VIS - Marking laser

Layout and connectivity

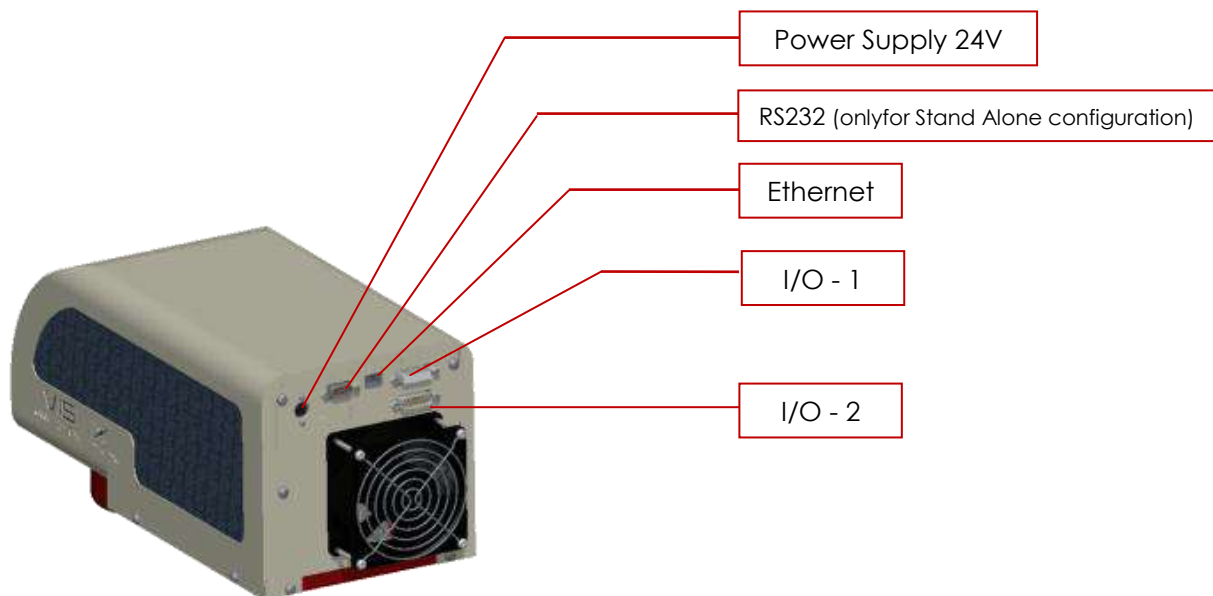

Lenses range

Lens F160	Flat field focus – marking area 110x110 mm • 4,33"x4,33"
Lens F100	Flat field focus – marking area 60x60 mm • 2,36"x2.36"
Lens F254	Flat field focus – marking area 155x155 mm • 7"x7"
Lens F420	Flat field focus – marking area 300x300 mm • 12,59"x12,59"

Lenses focus length (these data are can vary lens by lens with a tolerance of 5%)

Lens F160 (mm • in)	198 • 7,8
Lens F100 (mm • in)	120 • 4,7
Lens F254 (mm • in)	302 • 11,9
Lens F420 (mm • in)	520 • 20,5

Configurations

Basic Board

Stand Alone Board

I/O 15 Pins Female	Marking in action	I/O 15 Pins Female	Marking in action
	Laser abilitation		Laser abilitation
	Mark in progress		Mark in progress
	Enable laser		Enable laser
	Start marking		Start marking
	System ok		System Ok
	Laser On		Laser on
		Ready (job pronto)	
I/O 15 Pins Male	Diagnostica – Id driver	I/O 15 Pins Male	Diagnostica Id Driver
	Qswitch on		Q Switch on
	Term. Ok		Term ok
	Warm up		Warm up
	Current monitor		Current monitor
		4 User in	
		3 User out	
		Job selection button	

Available Software

Genius Plus Software

Software versatile in the applications and easy to use, even by operators without CAD knowledge. Three different configurations: BASIC version, STANDARD version and ADVANCED version.

- Complete management of the texts and arc texts with TrueType Font full compatibility
- Direct management of the basic drawing elements (rectangles, circles, polygons, arcs, etc), management of barcodes (Code 39, codebar, code 93, code 128 EAN / UCC128, interleaved 2 or 5 ITF, postnet, tuple, tuples, EAN 8, EAN 13, booklan), DATAMATRIX (ECC 200) and QR codes.
- Graphics and photos importable in Raster format (JPG, BMP, PCX, GIF).
- Drawings and logos importable in vector format (DXF, DWG, AI, CDR,

Automator VIS - Marking laser

- WMF, PLT, EMF).
- View and order management for marking objects, as well as ability to control external automations such as X and Y axes, Z axis Theta axis (rotary), delays and signal exchanges with the external environment.

Communication protocols

Available Communication Protocols: by TCP/IP and RS232. The protocol depends by the motherboard installed on the laser:

- In the BASIC version (connected to the PC that runs the software) communicates with the Remote Interface Protocol. This Protocol can upload programs, update fields inside the program and control the system's status
- From the STANDARD version can communicate with a PC by the Interface Protocol, but can also communicate directly with the laser without a PC, by the API protocol, still supporting the same editor and control features of the BASIC version
- The advanced version allow to manage all the features of the BASIC and STANDARD versions and can mark "on the fly".