



PRECISION ABRASIVE WATERJET ACCESSORIES

Equipment Specifications

MOBILE JMC



Mobile JetMachining Center Model 2652
shown with a Tilt-A-Jet® accessory



OMAX® Mobile JetMachining® Center

An extremely durable and reliable system specifically designed for the job shop on the go. Easily transport OMAX equipment on a regular basis with this platform configuration.

Completely assembled and factory tested, the Mobile OMAX JetMachining Center includes a Direct Drive Pump, Chiller, Water Softener System, and 100 lb Bulk Hopper for abrasive storage. Rapid, centralized setup for air, power, water, and drain allows operators to have an activated system in a matter of minutes.

The advantageous cutting solution for quick turnaround parts improves production uptime for the mining industries; onshore/offshore oil exploration and maintenance; large travelling ships; high-rise building construction; and other industries requiring a self-contained cutting shop in an ever changing work environment.

Mobile JMC

Standard Features

- Separate, on-board Bulk Hopper for accessing extra abrasive supply
- Water Softener System to treat regional hard water conditions
- Chiller System to cool water supply for the pump on a seasonal or regular basis
- System disconnect box with safety lockout feature
- Rapid Water Level Control for quiet and clean submerged cutting
- Epoxy-coated platform equipped with proven OMAX table, pump, and PC-based controller technology
- Major equipment mounted to a steel base with forklift access pockets
- Platform corners equipped with lifting eyes for convenient maneuvering with an overhead crane
- Tie-down rings along the platform sides for overall safe shipment and three specific centrally located tie-down rings for additional protection for the OMAX Pump and JetMachining Center
- Adjustable leveling foot located on the bottom of the PC-based controller to support the controller during shipment
- Adjustable PC-based controller's swing arm can be locked into any position during shipment and operation
- Flooring comprised of rubberized, non-skid and anti-fungal material

Benefits

- Entire system can be quickly and easily moved
- Entire system transportable in a standard shipping container
- Ideal cutting tool for oil field maintenance, high-rise steel construction, shipbuilding, military, commercial business sectors, and other mobile applications

Machine Availability

- Platform configurable with a Model 2626 or Model 2652

Connect and follow OMAX for the latest news in waterjet technology.



The OMAX Technology Guarantee entitles you, as the original owner, to free OMAX software upgrades for the life of the machine.

OMAX Mobile JetMachining Center

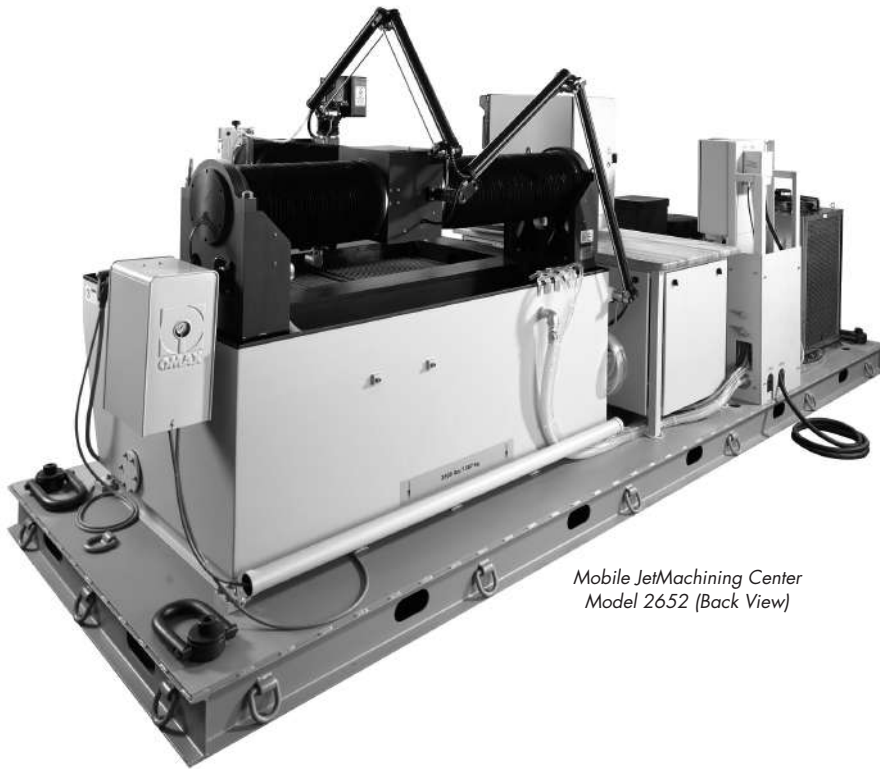

Mobile JetMachining Center
Model 2652 (Back View)

Optional Accessories

- OMAX MAXJET®5 MiniJet Nozzle Assembly
- Water-only MAXJET 5 for cutting soft materials
- Tilt-A-Jet Cutting Head for taper compensation
- Splash Shield
- Material Holding Kit
- Laser Feature Finder
- Waterjet Brick Kit
- Precision Optical Locator (POL)
- Manual Tilt Z
- Z-axis Drill
- Collision Sensing Terrain Follower (CSTF)
- Rotary Axis

For more available accessories, contact an OMAX sales representative.

Mobile JetMachining Center Specifications

Model	DIM "X"	DIM "Y"	X-Y Cutting Travel
2626	~205"* (~5,207 mm*)	75" (1,905 mm)	29" x 26"*** (737 mm x 660 mm**)
2652	231" (5,868 mm)	75" (1,905 mm)	52" x 26"*** (1,321 mm x 660 mm**)

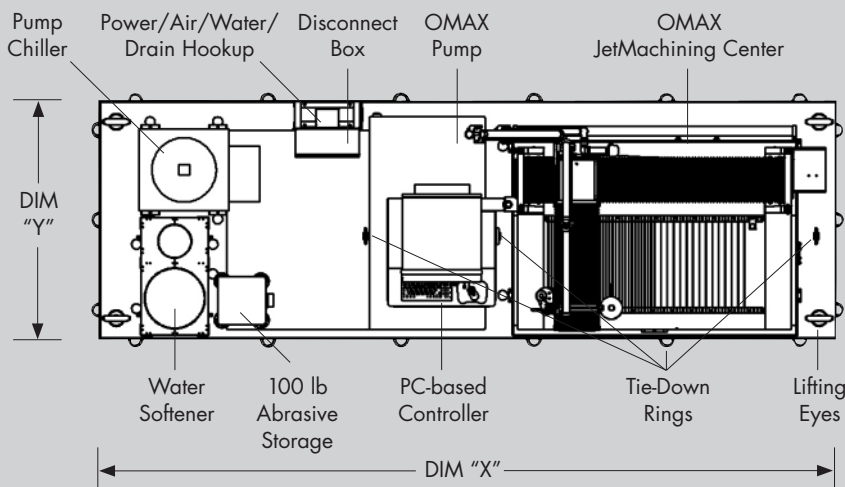

* Preliminary estimated dimension

** Optional accessories may reduce X-Y Cutting Travel. Contact OMAX for more information.

Note: Specifications subject to change without notice. Check for the latest version at www.omax.com.

About OMAX

OMAX has the industry leading patented abrasivejet controller with a built-in expert system. Our exclusive "Compute First-Move Later" motion control system automates most programming and tool setup work, virtually eliminating the need for extensive operator training. Plus, with free OMAX Intelli-MAX® Software upgrades for the life of the machine and our ongoing commitment to advance the efficiency of our technology and software, OMAX saves you time and money.

For information on what other OMAX products and accessories can do for you, call us today at 800-838-0343 or visit our website at www.omax.com.



OMAX Corporation

21409 72nd Ave South, Kent, WA 98032

253-872-2300 tel 253-872-6190 fax

1-800-838-0343 toll-free

WWW.OMAX.COM website

Printed in the U.S.A © June 2011 All rights reserved. S-0047