

ARENA - Marking Laser Enclosure

Safety class 1

System Overview

Benchtop structure with automatic opening front door and big inspection window to check the marking area. Designed for medium productions, ARENA is small and compact. The door opening system is electropneumatic. It's a Safety Class 1 device. On the front door a wide window allows the operator to control the laser marking activity. The activation of the inner Z axis is electric: a software driven Z axis version is available for **FYBRA**, **VIS** and **greenVIS**.



ARENA sets all the Automator marking laser sources: **nanoVIS**, belonging to the new family of Automator's **aWave** products with frequency auto-control; **VIS**, innovative one-block laser with YVO4 source in OEM version 10, 20, 30 and 40W; **greenVIS**, innovative one-block green laser in version 3, 5 and 10W; **FYBRA**, the new powerful fiber laser with 22, 33 and 54W. The managing software allows the operator to mark anything, even complex logos, serial numbers and data matrix.

ARENA, requires a PC, not included.

Configuration

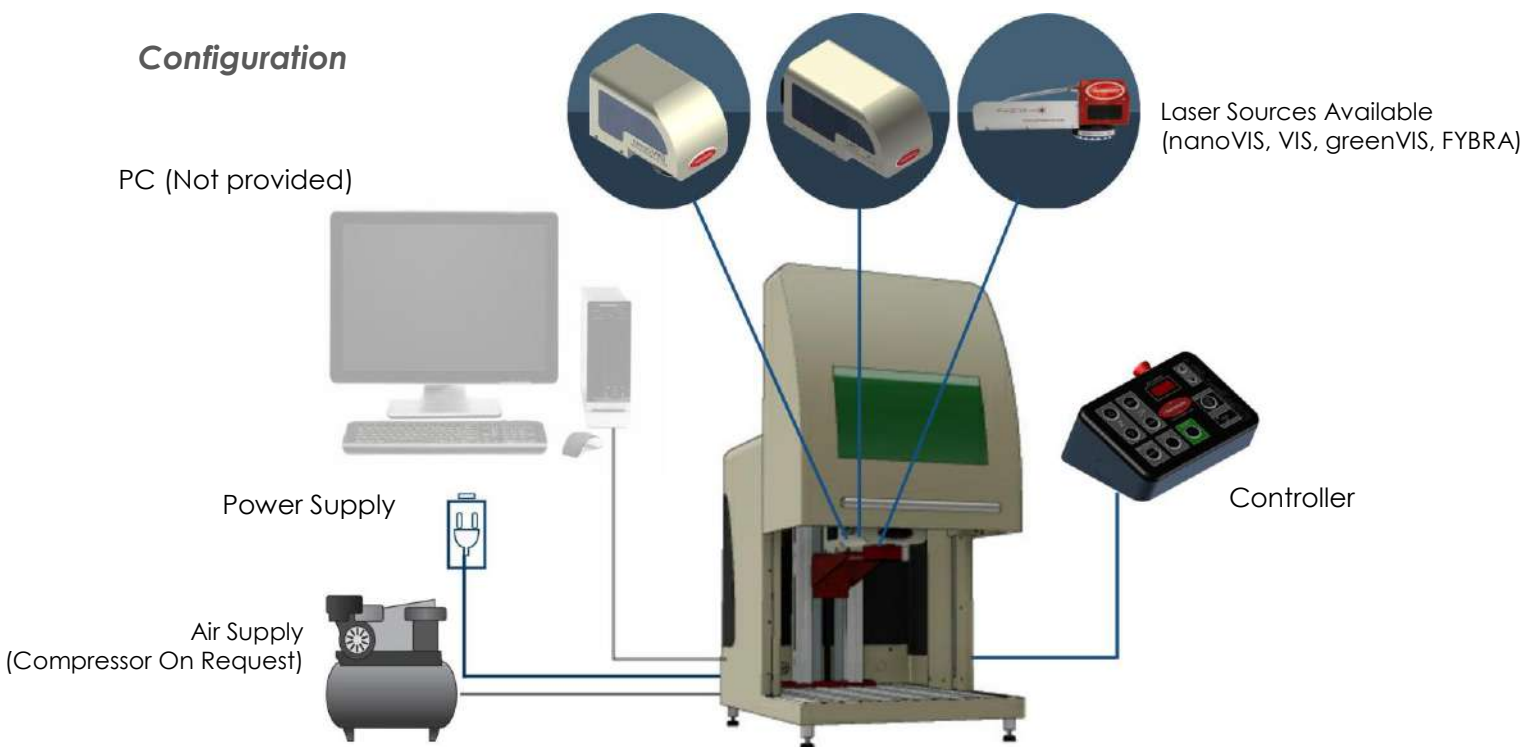

Optionals

Adjustable/software driven Z axis, Rotating Theta axis, automatic focus detection device FocusFinder, dust extraction system

Automator ARENA - Marking Laser Enclosure

Technical drawings

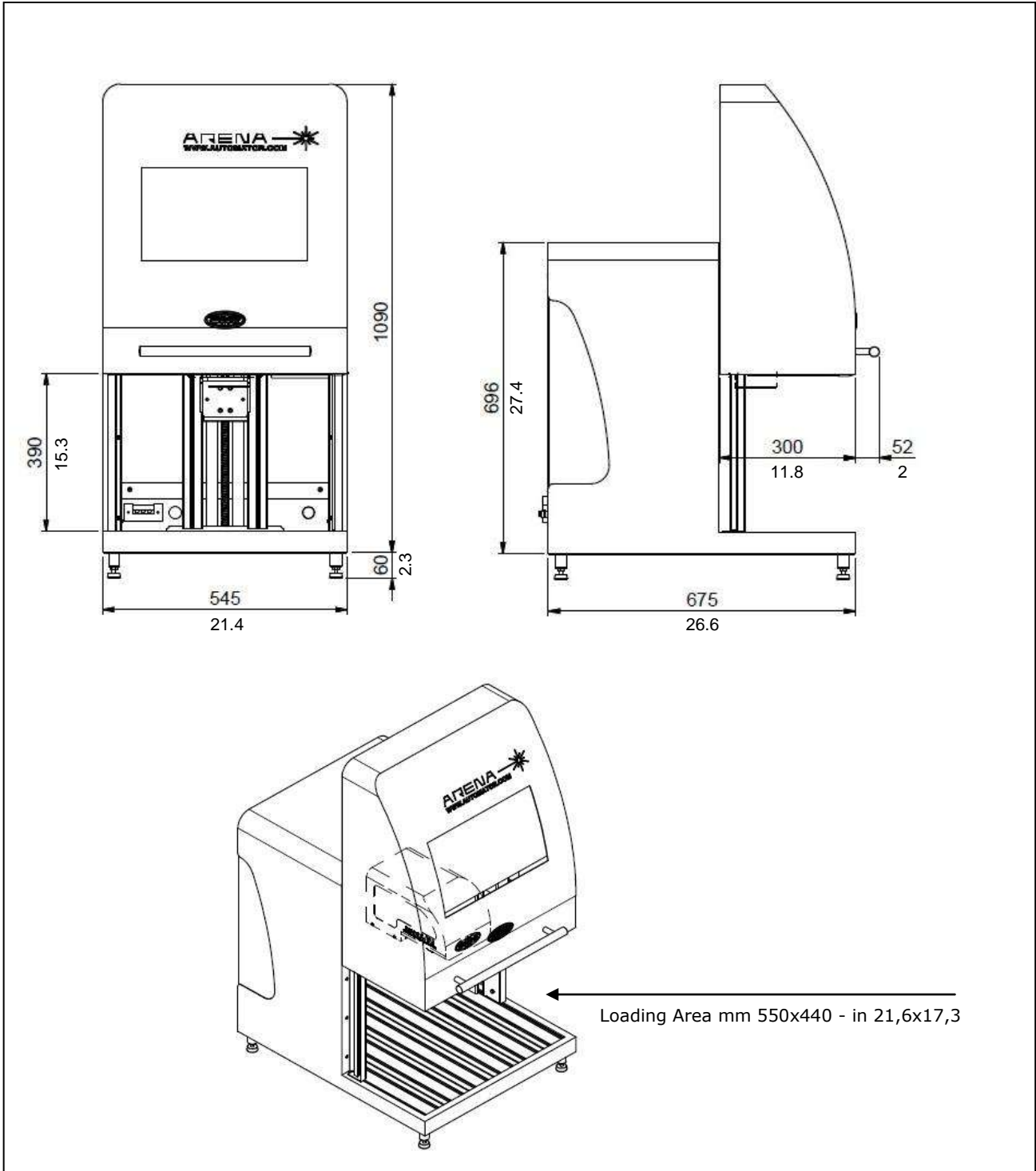

Automator ARENA - Marking Laser Enclosure

Technical data

Overall Dimensions: LxWxH (mm • in):	Open - 727x545x1140 • 28,6x21,4x44,9 Closed - 727x545x756 • 28,6x21,4x29,7
Weight (kg - lb):	11 • 56,21
Maximum door opening height (mm • in):	390 • 15,3
Loading area (mm • in):	550x440 • 21,6x17,3
Loading area with Software driven Z axis (mm • in):	545x435 • 21,4x17,1
Maximum markable item height (mm • in):	With standard lens F160 = 220 • 8,6
Optical Isolator:	YES
External power supply:	100/240V 50/60Hz
Opening Door pneumatic system (bar):	Minimum 4
Z axis drive mode:	Electric
Operating temperature (°C • °F):	+15 - +39 • 32 - 100,4
Store temperature (°C • °F):	+5 - +60 • 14 - 140
Humidity (%):	30 - 85
Cooling system:	Forced air cooled - Water (optional)
Connectivity:	Power supply, air supply, passwall, USB port
Directive 2011/65/EC - Restriction of Hazardous Substances (RoHS):	Respectful
Safety Class:	1
MTBF (Working Hours):	140.000
IP Certification of the Cover: (CEI70-1)	30
Available axis (depending by the softwares):	Vertical Z and Rotating Theta

Red Pointer Diode

Inside the enclosure, the laser source produces a red, visible light, known as pointer, which allows visualizing the working area directly on the surface of the object, without altering it's nature or starting the marking. For the wavelength, the operator does not need to wear the DPI protection, while he proceeds for the setting, the programmation or the marking trials of the laser.

Automator ARENA - Marking Laser Enclosure

Layout and connectivity

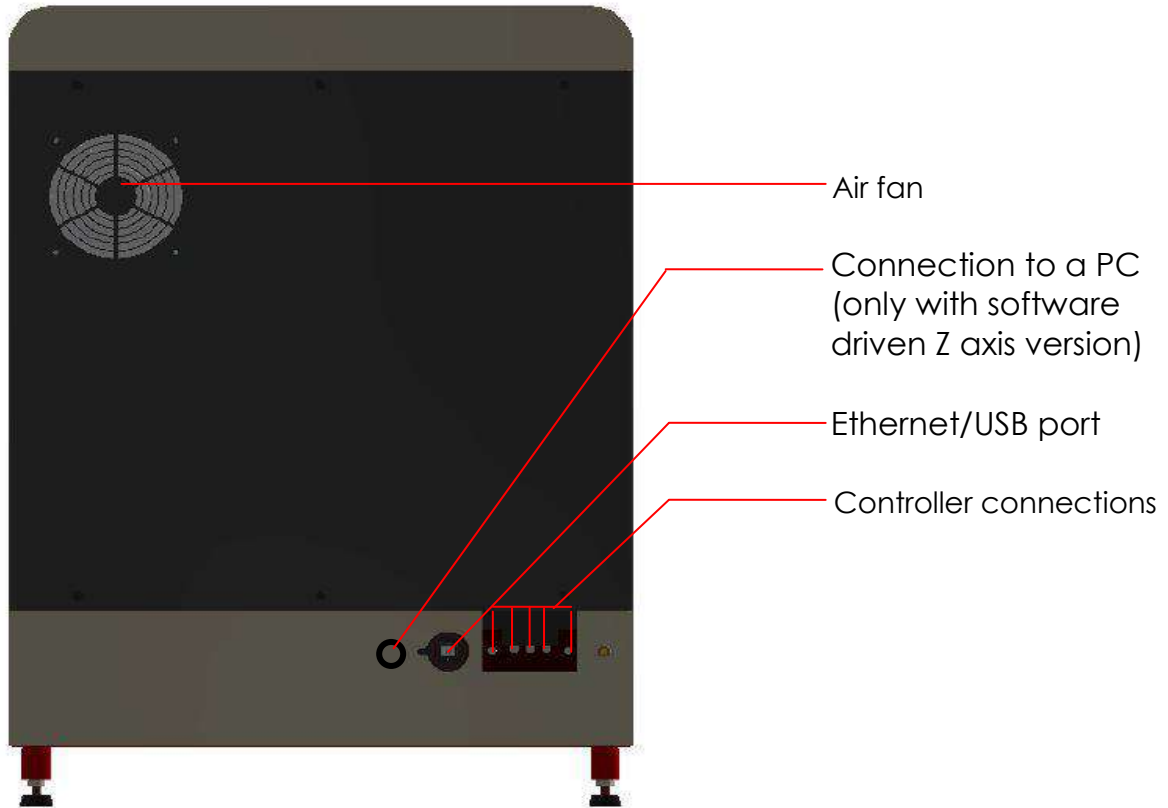

Lenses range

Lens F160	Flat field focus – marking area 110x110 mm • 4,33"x4,33"
Lens F100	Flat field focus – marking area 60x60 mm • 2,36"x2.36"
Lens F254	Flat field focus – marking area 180x180 mm • 7"x7"

Focus lengths(FYBRA and nanoVIS)

Lens F160	177mm • 6.96"
Lens F100	107mm • 4.21"
Lens F254	301mm • 11.85"

Focus lengths(VIS and greenVIS)

Lens F160	198mm • 7.8"
Lens F100	120mm • 4.7"
Lens F254	302mm • 11.9"

Automator ARENA - Marking Laser Enclosure

Controller

ARENA is activated and managed via console that allows the Z axis drive system and the front door electro-pneumatic opening system. The external controller has a specific command layout for every laser source set inside the ARENA enclosure.

Overall dimensions (mm • in)	229x188,3x115,5 • 9x7,4x4,5
Weight (KG • lb)	2,9 • 6,3
Power supply:	110/240 VAC

Technical drawings

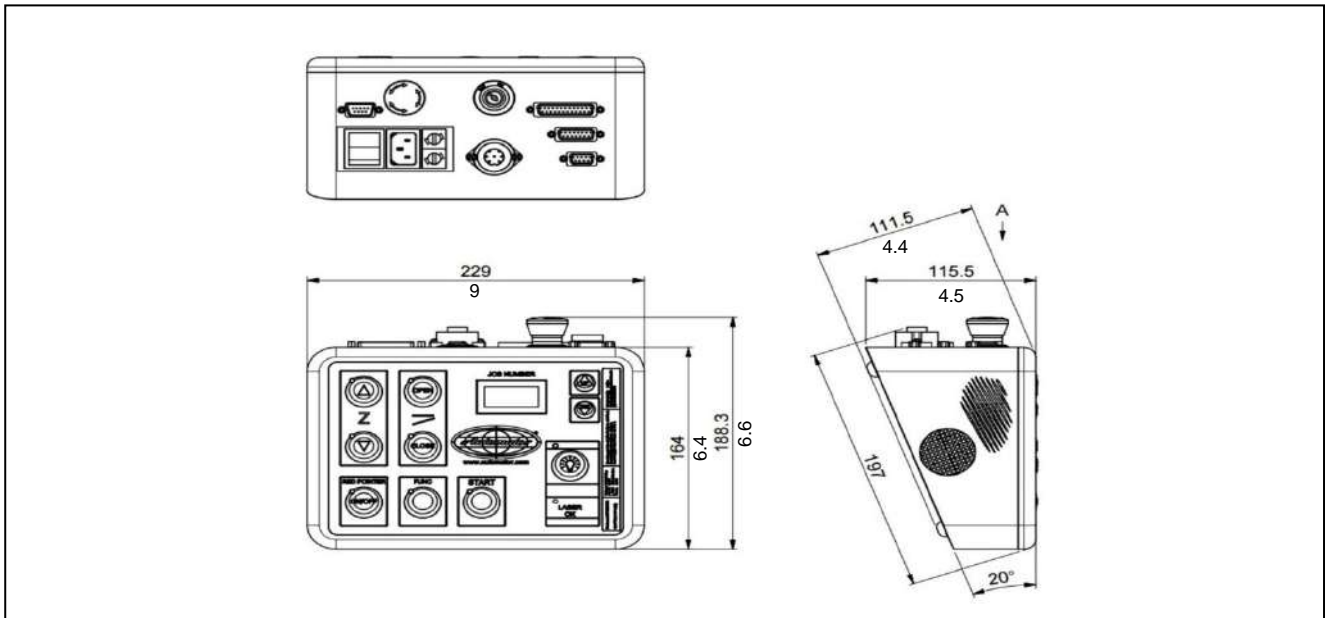

Layout and connectivity

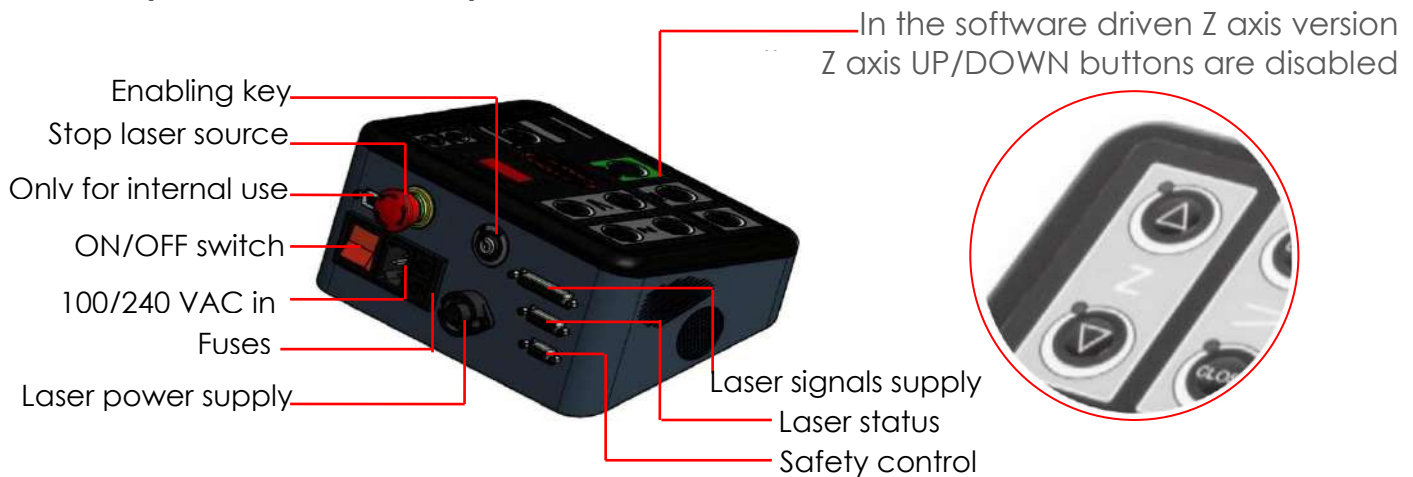

Automator ARENA - Marking Laser Enclosure

Available Softwares

ARENA laser system can mark everything by two different Software offerings: the Nano Standard Software and the Genius Plus:

Nano Standard Software

Software versatile in the applications and easy to use, even by operators without CAD knowledge.

- Multilanguage menu
- Management barcode "Datamatrix", 2D code, QR code, PDF Queues
- Easy import of vector drawings
- Easy import of raster graphics
- Complete set of laser parameters such as speed or power laser
- Texts, Text arcs, text on curved lines, rectangles, polygons, circles and arcs
- File DXF, WMF, AI, SVG, MF, DST, NC, .G, PLT, EMF, BMP, JPG, EPX, PCX, GIF, PNG, TIFF
- TTF Font ® (windows property)
- Graphical preview
- Texts with date, serial numbers, shift codes and year/month/day
- Markings filled or only profile
- Templates (object to be marked as background)
- Proportion scale, move, rotate, group creation of each object on the screen

No Communication protocols needed

Genius Plus Software

Software versatile in the applications and easy to use, even by operators without CAD knowledge. Three different configurations: BASIC version, STANDARD version and ADVANCED version.

- Complete management of the texts and arc texts with TrueType Font full compatibility
- Direct management of the basic drawing elements (rectangles, circles, polygons, arcs, etc), management of barcodes (Code 39, codebar, code 93, code 128 EAN / UCC128, interleaved 2 or 5 ITF, postnet, tuple, tuples, EAN 8, EAN 13, booklan), DATAMATRIX (ECC 200) and QR codes.
- Graphics and photos importable in Raster format (JPG, BMP, PCX, GIF).

Automator ARENA - Marking Laser Enclosure

- Drawings and logos importable in vector format (DXF, DWG, AI, CDR, WMF, PLT, EMF).
- View and order management for marking objects, as well as ability to control external automations such as X and Y axes, Z axis Theta axis (rotary), delays and signal exchanges with the external environment.

Communication protocols

Available Communication Protocols: by TCP/IP and RS232. The protocol depends by the motherboard installed on the laser:

- In the BASIC version (connected to the PC that runs the software) communicates with the Remote Interface Protocol. This Protocol can upload programs, update fields inside the program and control the system's status
- From the STANDARD version can communicate with a PC by the Interface Protocol, but can also communicate directly with the laser without a PC, by the API protocol, still supporting the same editor and control features of the BASIC version
- The advanced version allow to manage all the features of the BASIC and STANDARD versions and can mark "on the fly".

Configurations

Software driven Z axis version

In this configuration, the laser moves up and down and focuses automatically to the programmed marking position. The vertical Z axis is driven only by the **GeniusPlus Software**, through an electric stepping motor: once the marking job is launched, the system moves automatically the marking head in the programmed marking position. This new feature doesn't change the focal distance of the laser lenses or the maximum height of the item to be marked. This configuration requires that the operating PC MUST HAVE a PCI slot for the external axis managing motherboard and is run only with the GENIUS PLUS software.

ARENA with Security box activation

In this configuration, ARENA can be activated by the Automator Security box, choosing the correct setting on the controller (setting n.3 for nanoVIS and n.4 for VIS or FYBRA) and pushing both the buttons on the front. This configuration is perfect to ensure more safety to the marking operator.



Automator ARENA - Marking Laser Enclosure

ARENA Workstation

Reinforced aluminum bench designed to support the ARENA marking system different laser sources. The bench, which can be easily used both by right-handed and left-handed operators, can be moved easily thanks to the wheels on the base, allowing the creation of a flexible work station, complete and adaptable to any marking application.

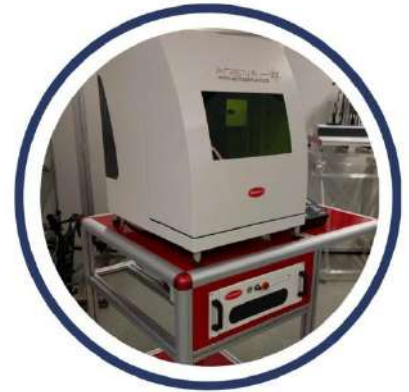

Technical drawings

