

ADP25120- Dot Peen Marking Machine

Marking area 25x120mm / 1x4.6"

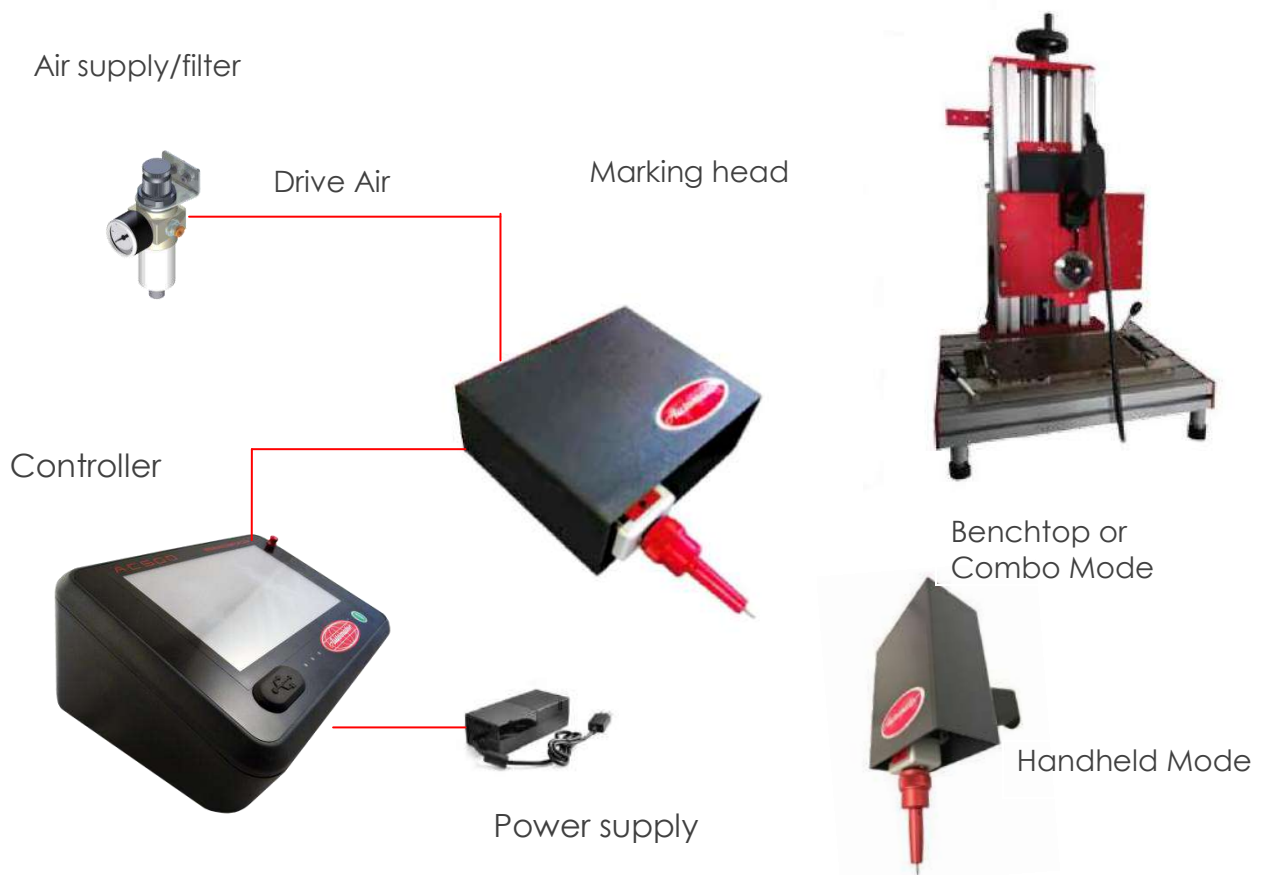

- **High quality at higher speed**
- **Extremely precise and reliable**
- **COMPACT marking unit**
- **Easy integration with PLCs and Host Computers**
- **TTF, 2D codes, arcs and logos**
- **Unlimited range of stored marking programs**

System overview

ADP 25120 is a very small system designed for portable and easy integration applications. It marks permanently different materials, such as metals, aluminum, iron, cast, plastic... and many others, with a pin with drive air and spring return. The characteristics of the message to be marked are all different and easily set by software, such as height and width of the character, marking position in the window, the font, the parameters of work and communications. Two axes, X and Y each powered by a stepper motor, determine the movement of the pin and the precision of the point in the marking window of the specific model.

The system consists of:

- Marking Head with cartridge, cable and pin
- Controller
- Filter
- Power supply

ADP 25120 - Dot Peen Marker

System Scheme

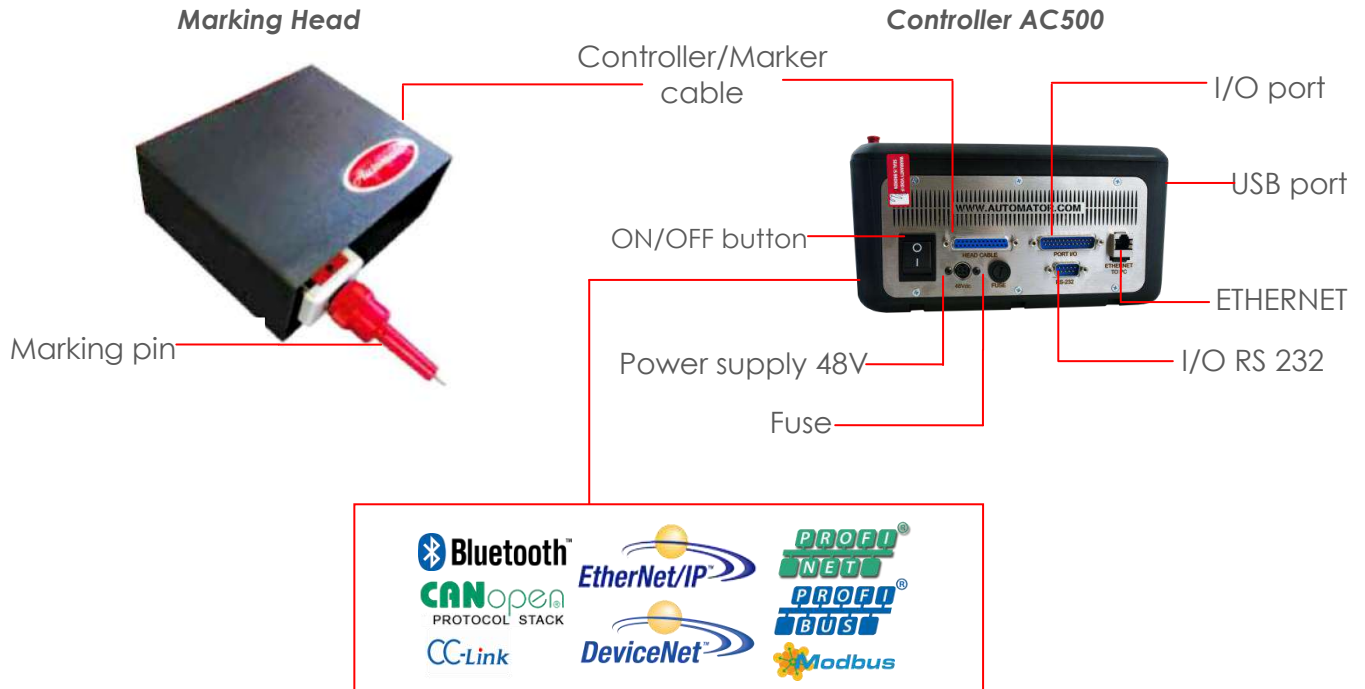

Optionals Communication protocols (go to page 5)

System Marking Modes

- **Controlled dot** – The provided software allows the marking of font characters, (5x7, 11x16 etc..) where for each point the head activates the solenoid that moves the pin. Thanks to a specific parameter operating character, you can specify the density of points to be marked, typically expressed in dots / cm. The mode of the controlled point (dot) is recommended for marking of high quality and definition.
- **Vibrating dot** – The solenoid valve which controls the pin is in working "open" condition throughout all the operative process of the object to be marked. Also, thanks to the combined action of compressed air and spring return in the cartridge, the pin comes in small vibration and composes the message. The vibration mode is recommended for marking and consequently very fast in very short time

Marking Head

The ADP 25120 head has a marking area of 25x120mm, using a pin that moves on X and Y axes with high precision. The shutter plates at the base of the cartridge protect the internal moving parts from dirt and waste.

Marking Head - Technical data

Overall dimensions: LxWxH (mm inches):	199 x 174.5 x 80 mm / 7.8 x 6.9 x 3.1 "
Weight (kg lbs):	4 Kg / 8.8 lbs
Marking area (mm inches):	25 x 120 mm / 1 x 4.7 inches
Power supply (V):	100 – 240 VAC / 50 – 60 Hz / 2 A
Air supply (Bar):	1 – 8 Bar
IP certification of the Cover:	IP54 (Equipped with protective rubber boot)
Working temperature (°C - °F):	0 – 50 °C / 32 – 122 °F
Stock temperature (°C - °F):	-10 – 59 °C / 14 – 138 °F
Humidity (%):	10% to 75% non-condensing
Cartridges available:	DOT3 – DOT6 – DOT12 – VIB3 – VIB4
Pins available	DOT3 – DOT6 – DOT12 – VIB3 – VIB4 (All Carbide)
Connectivity:	AC500 – AC250

Marking head - Marker/Controller cable

Super flexible cable for continuous marking applications, which connects the controller to the marking head. Available in different lengths.

Marking head - Marking speed

The speed depends on various factors, such as the font height, the scribe depth, the desired quality and so on. With standards fonts height, the system can mark 3 characters per second.

Marking head - Marking depth

The depth of mark depends on the drive air pressure and on the material of the item to be marked. On aluminum with a thickness of about 1 mm | 0.40", a marking depth of 0.85 mm | 0.03" it's possible. In thinner materials, the marking depth may increase. In cold rolled steel a marking depth up to 0.5 mm (0.02") it's possible.

Marking head - Noise

When the marking system is set a 50% of its maximum level, its noise level has been measures at 74,6 dB (using the "time weighted average PPROACH (average sound exposure over an 8 hour period). Noise-level Tests have been carried out under controlled conditions, imitating as closely as possible industrial normal operations. Conditions such as the kind of surface to be marked, its shape and material, the rigidity of the working table and the ambient noise can alter the actual noise level.

Marking Head - Marking vibrations

Vibrations tests are referred to hand-arm (VM) and were performer under controlled conditions as closely as possible to standard industrial operations. Vibrations tests results: Steel marking surface Pin 3mm MB 0,4m/s T(eav) >24H T(elv) >24H Pin da 6mm MB 0,8m/s T(eav) >24H T(elv) >24H Aluminum marking surface Pin da 3mm MB 0,6m/s T(eav) >24H T(elv) >24H Pin 6mm MB 1,2m/s T(eav) >24H T(elv) >24H Conditions, such as the support, the rigidity of the work piece, the material and the setting of the machine can alter the actual vibration level.

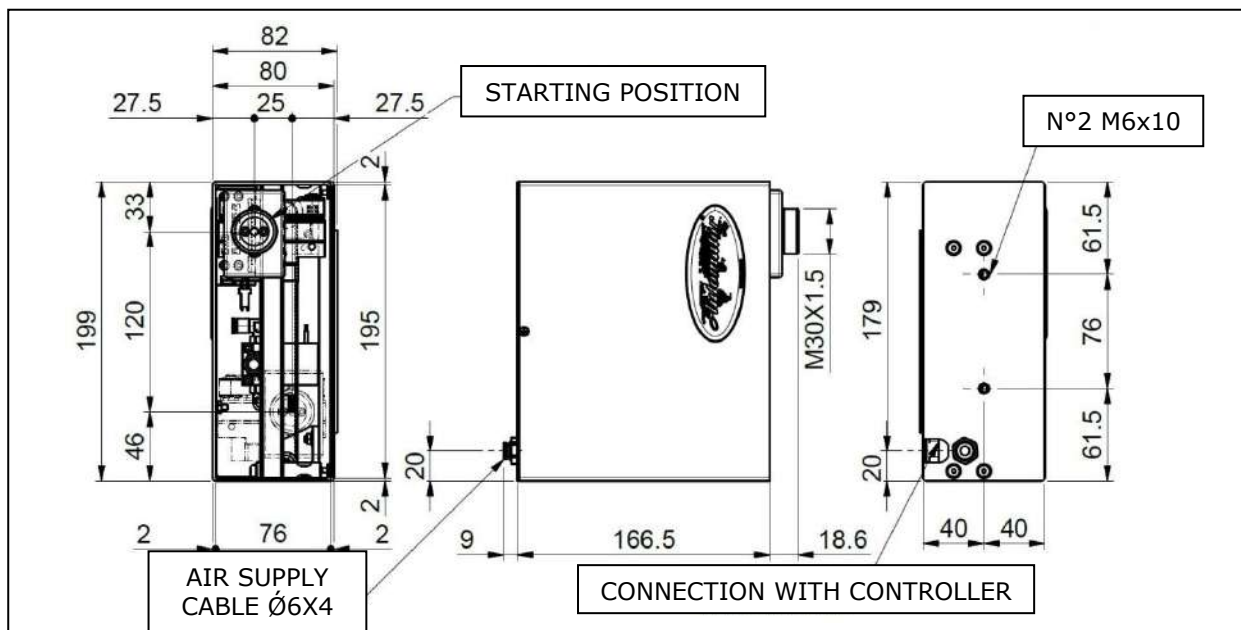
Marking Head - Technical drawings

Marking Head - Available pins

Vibro (mm / inches)	3 / 0,11" 4 / 0,15"
Controlled (mm / inches)	<ul style="list-style-type: none"> • 3 / 0,11" • 3 XL / 0,11" XL • 3 / 0,11" stroke +20 / +0,78" • 6 / 0,23" • 6 XL / 0,23" XL • 12 / 0,47"
Vibro Cartridge (mm / inches)	3 / 0,11" with return spring 4 / 0,15" with return spring
Controlled Cartridge (mm / inches)	<ul style="list-style-type: none"> • 3 / 0,11" • 3 / 0,11" stroke +20 / +0,78" • 6 / 0,23" • 12 / 0,47"

Universal Controller AC500
Controller AC500

The **Automator Universal Controller AC500**, with a 7" touch screen display, allows an easy and intuitive navigation in the software program, thanks to its stylus pen. Equipped with Serial port, USB interface and I / O connector, located on the rear, the controller is available in both bench and panel version for integrations.



Controller AC500 - Technical Data

Overall dimensions LxWxH (mm inches):	230x165x110 9x6.5x4.3"
Weight (kg lbs):	2,3 5
Material of the cover:	Special fire proof resin material
IP certification of the cover:	42
Power supply (V):	48Vdc
External power supply:	110/220V 90-230V 50 - 60Hz
Humidity (%):	10-79 Not Condensed
Working temperature (°C °F):	0-45 32 - 113 Not condensed
Fixed Memory Card (MB)	64
Connectivity:	RS232, RS485, Ethernet, Usb, I/O

Controller AC500 - External power supply

AC500 external power supply complies with the following directives:



Controller AC500 - Filter

Pressure regulator with filter for drive air

Controller AC500 - Technical Drawings

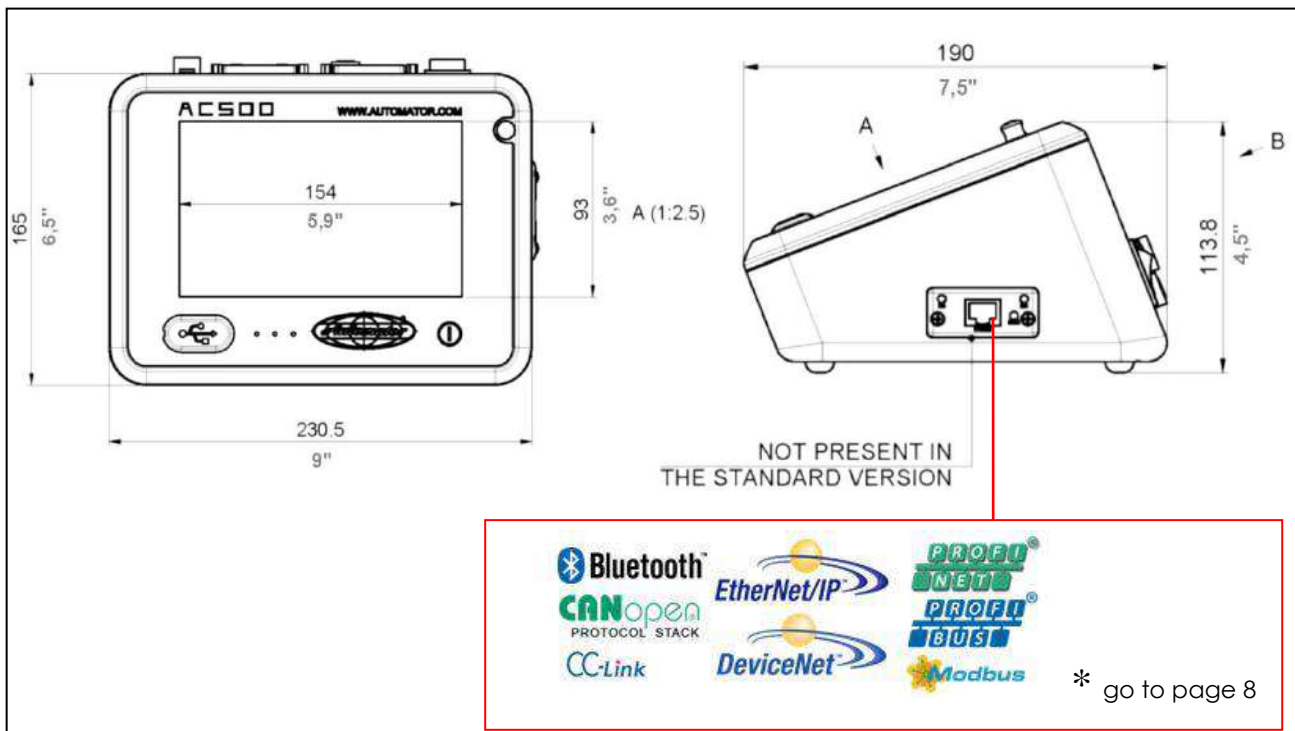

ADP 25120 - Dot Peen Marker

Controller AC500 - Scheme

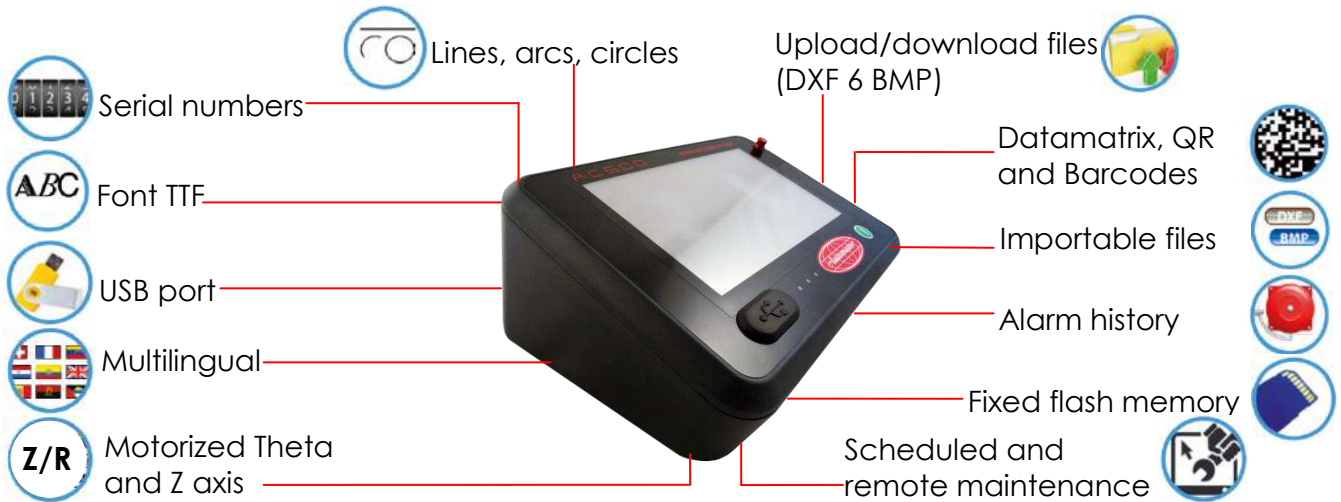

Controller AC500 - Optionals

- Bar Code Scanners and 2D Code Readers
- Foot Start/stop button
- Logo and font generator software

WARNING

Do not block air vents on the side of the case. The marking system must be electrically isolated from any other device that may generate electromagnetic interference.

Universal Controller Software

The AC500 coupled with our Automator software allows an intuitive user interface with absolute graphic flexibility. Thanks to the touch screen graphic display, it is easy to navigate and to create messages to be marked and parameters.

The preview allows to represent exactly what will be marked and any change in the message will be displayed instantly. The software provides for the creation of messages with the date in various formats, fix or variable texts, codes, serial numbers, Datamatrix and logos. Possible the creation of the programs on the PC (running Windows operating systems), which can be easily transferred to the AC500 controller with USB stick or USB connection.



Host Communications

The AC500 software allows you to set the communication parameters to share data with a host computer, supporting RS-232 and RS-485 serial communication protocols and Ethernet TCP/IP interface. The software provides two different communication protocol modes:

- Programmable Protocol
- Extended Protocol

The serial RS-232 communications interface is available for remote devices: host computers, terminals, or scanners/readers.

The Ethernet (TCP/IP) interface is available for host computers working over a LAN (Local Area Network).

The RS-485 interface is available for multi-drop networks or long transmission distances or of up to 31 AC500 controllers.

Programmable Protocol

The programmable protocol is available for QR, barcodes and Datamatrix readers:

- no error checking or alarm/messages about data to be marked
- Starting character defines where the software begins to count character positions
- Terminating Character defines the end of the data to be read
- Character Position counted from the starting character independently by all the previous characters
- Variable length messages available

Extended Protocol

The extended protocol is bidirectional and available for marking applications that need serial communications. It includes error checking/alarm and a range of transmission messages Types: SOH, TYPE, [##] , STX, [DATA], ETX, BCC, CR

- SOH (ASCII) - The AC500 controller ignores all characters received before the SOH.
- TYPE (printable ASCII character) - It defines the types and content of the message from the host

Type 1 - It overwrites a field in the loaded marking with data from the Host.

Type P - It specifies the marking name to be loaded

Type Q - It updates the marking to be printed with new infos from the host to be placed in the Query table

Type V - It updates the variable text in a field of the current marking with infos from the Host.

Type O - It sends the marker to the online position

Type G - It sends a start print command for the current marking program

Type I - It returns a status hexadecimal code

- [##] - It specifies the Station ID of the AC500 for multi-drop network applications (Range: 00-31)

ADP 25120 - Dot Peen Marker

- STX (ASCII Start of Text Character: 002H)
- ETX – (ASCII text ending character: 003H)
- [DATA] - Optional character string for message types like Type 1, P, Q, and V
- BCC - Optional Block Check Code to improve link reliability by providing fault detection

Configurations

In addition with the production lines integration mode, ADP2560 can be set on a toolstand for workstation marking applications

Benchtop configuration

Aluminum toolstand with Z axis adjustment knob adjustable for the surface to be marked.

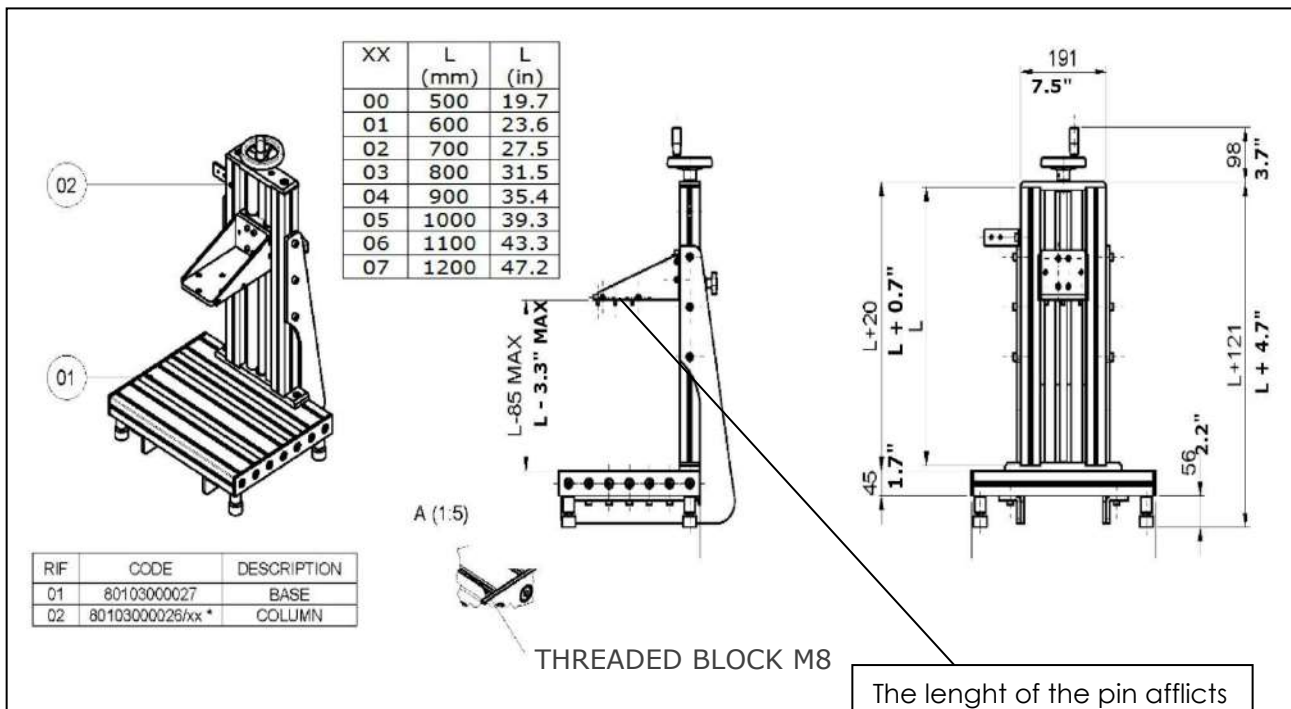
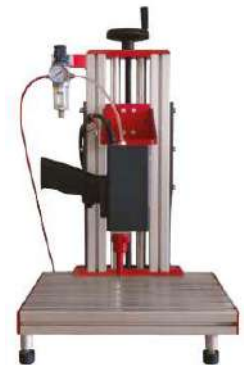

The length of the pin afflicts the maximum height of the item to mark:

VIBRO (mm/inches)
 3/0,11": 330/13"
 4/0,15": 330/13"
 CONTROLLED
 3/0,11": 302/12"
 6/0,23": 305/12"
 12/0,47": 291/11.5"

ADP 25120 - Dot Peen Marker

Portable configuration

Portable structure for ADP2560 head, with pistol handheld system adjustable in relation to fixed the cartridge / pin. The cable head-controller is 4mt long.

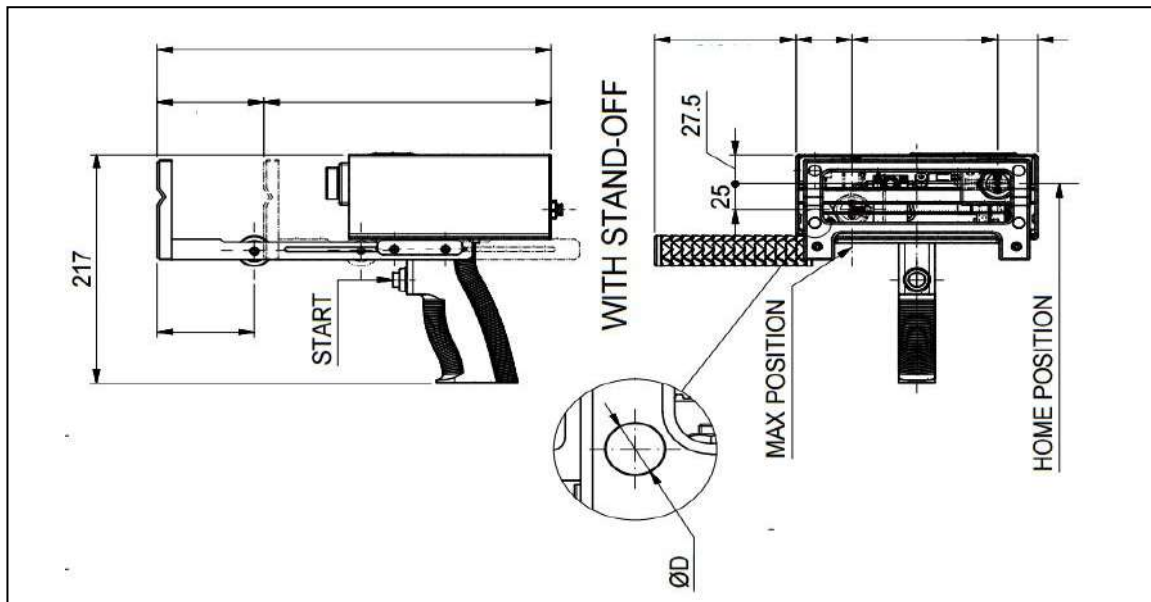

Combo-kit Configuration

In this configuration, the ADP25120 is set with a toolstand (standard or special height), with a special handheld and housing basket, to be used both in bench or portable mode. A special unlocking system allows the operator to separate the marking head from the toolstand to use it directly on the part to be marked.

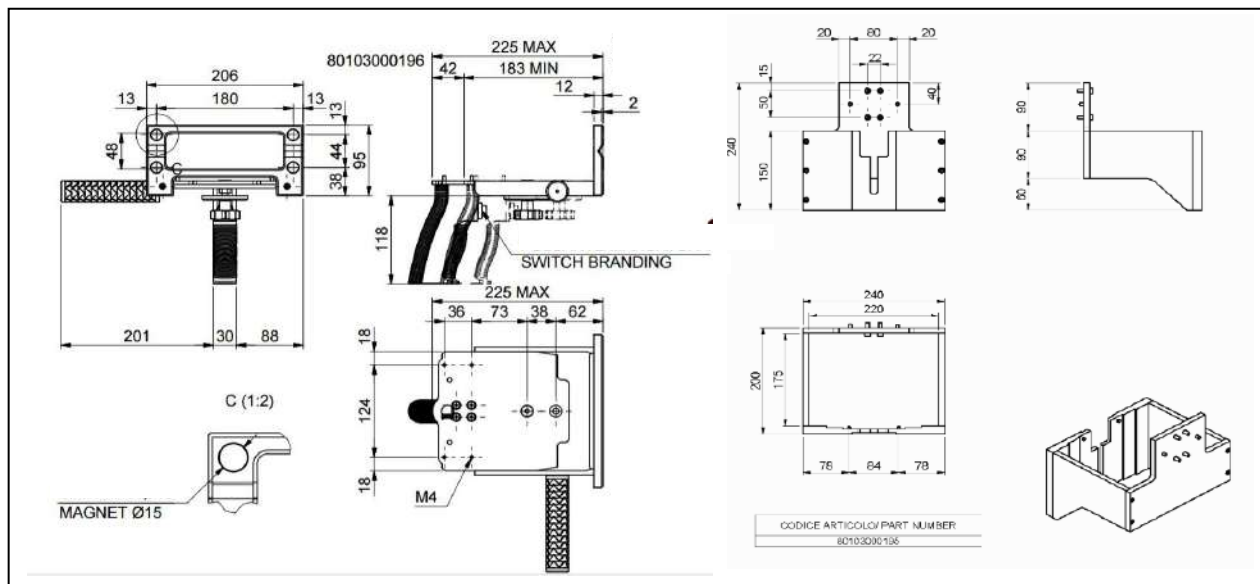

*TRADEMARKS

Automator, ADP and AC500 are registered trademarks of Automator International Srl.
 Windows is a registered trademarks of Microsoft Corporation
 Bluetooth is a registered trademark of Bluetooth SIG, Inc.
 CanOpen is a registered trademark of CAN in Automation Inc
 CCLink is a registered trademark of Mitsubishi Inc.
 Ethernet/IP and DeviceNet are registered trademarks of Rockwell Automation.
 ProfiNet and ProfiBus are registered trademarks of Profibus Inc.
 ModBus is a registered trademark of Schneider Automation